



BEARING UNITS



PILLOW BLOCKS - Standard Shaft Height

SBPE 200 Series

Normal Duty
Set Screw Locking
Solid Base

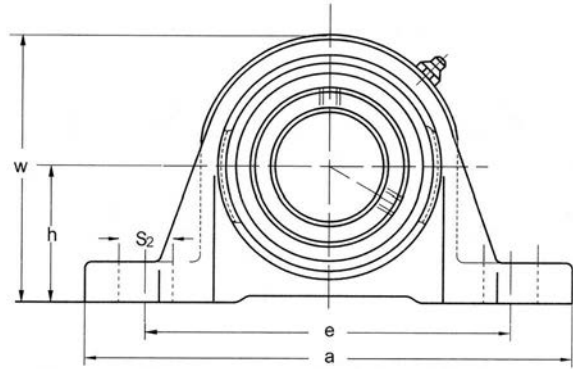
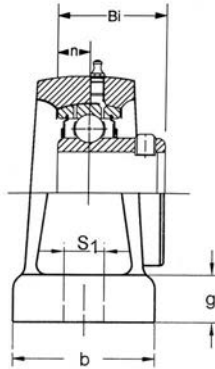

Unit No.	Shaft Dia.		Dimensions inch / mm									Bolt Size	Bearing No.	Housing No.	Weight Lbs kg	
	In.	mm	h	a	e	b	S1	S2	g	w	Bi					n
SBPE 201-8 202-10	1/2 5/8		1-3/16 30.2	4-7/8 123.8	3-3/4 95.3	1-7/32 31.0	7/16 11.1	19/32 15.1	9/16 14.3	2-1/4 57.2	0.866 22.0	0.236 6.0	3/8 M10	SB 201-8 202-10	PE203	0.88 0.40
SBPE 204 204-12	3/4	20	1-5/16 33.3	5 127.0	3-3/4 95.3	1-1/2 38.1	1/2 12.7	5/8 15.9	19/32 15.1	2-9/16 65.1	0.984 25.0	0.276 7.0	7/16 M12	SB 204 204-12	PE204	1.10 0.50
SBPE 205 205-14 205-15 205-16	7/8 15/16 1	25	1-7/16 36.5	5-1/2 139.7	4-1/8 104.8	1-1/2 38.1	1/2 12.7	5/8 15.9	5/8 15.9	2-3/4 69.9	1.063 27.0	0.295 7.5	1/2 M14	SB 205 205-14 205-15 205-16	PE205	1.54 0.70
SBPE 206 206-17 206-18 206-19 206-20	1-1/16 1-1/8 1-3/16 1-1/4S	30	1-11/16 42.9	6-1/2 165.1	4-49/64 121.0	1-7/8 47.6	21/32 16.7	13/16 20.6	23/32 18.3	3-9/32 83.3	1.181 30.0	0.315 8.0	1/2 M14	SB 206 206-17 206-18 206-19 206-20	PE206	2.20 1.00
SBPE 207 207-20 207-21 207-22 207-23	1-1/4 1-5/16 1-3/8 1-7/16	35	1-7/8 47.6	6-9/16 166.7	5 127.0	1-7/8 47.6	21/32 16.7	13/16 20.6	3/4 19.1	3-11/16 93.7	1.260 32.0	0.335 8.5	1/2 M14	SB 207 207-20 207-21 207-22 207-23	PE207	2.86 1.30
SBPE 208 208-24 208-25	1-1/2 1-9/16	40	1-15/16 49.2	7-1/4 184.2	5-25/64 136.9	2-1/8 54.0	21/32 16.7	31/32 24.6	3/4 19.1	3-15/16 100.0	1.339 34.0	0.354 9.0	1/2 M14	SB 208 208-24 208-25	PE208	3.85 1.75
SBPE 209 209-26 209-27 209-28	1-5/8 1-11/16 1-3/4	45	2-1/8 54.0	7-15/32 189.7	5-3/4 146.1	2-1/8 54.0	21/32 16.7	31/32 24.6	25/32 19.8	4-1/4 108.0	1.614 41.0	0.374 9.5	1/2 M14	SB 209 209-26 209-27 209-28	PE209	5.25 2.39
SBPE 210 210-30 210-31 210-32	1-7/8 1-15/16 2S	50	2-1/4 57.2	8-1/8 206.4	6-1/4 158.8	2-3/8 60.3	25/32 19.8	31/32 24.6	7/8 22.2	4-1/2 114.3	1.693 43.0	0.393 10.0	5/8 M16	SB 210 210-30 210-31 210-32	PE210	6.45 2.93